



**File Name:** cadillac 2006 cts manual.pdf

**Size:** 2241 KB

**Type:** PDF, ePub, eBook

**Category:** Book

**Uploaded:** 8 May 2019, 14:49 PM

**Rating:** 4.6/5 from 847 votes.

**Status:** AVAILABLE

Last checked: 13 Minutes ago!

**In order to read or download cadillac 2006 cts manual ebook, you need to create a FREE account.**

[\*\*Download Now!\*\*](#)

eBook includes PDF, ePub and Kindle version

[Register a free 1 month Trial Account.](#)

[Download as many books as you like \(Personal use\)](#)

[Cancel the membership at any time if not satisfied.](#)

[Join Over 80000 Happy Readers](#)

### Book Descriptions:

We have made it easy for you to find a PDF Ebooks without any digging. And by having access to our ebooks online or by storing it on your computer, you have convenient answers with cadillac 2006 cts manual . To get started finding cadillac 2006 cts manual , you are right to find our website which has a comprehensive collection of manuals listed.

Our library is the biggest of these that have literally hundreds of thousands of different products represented.





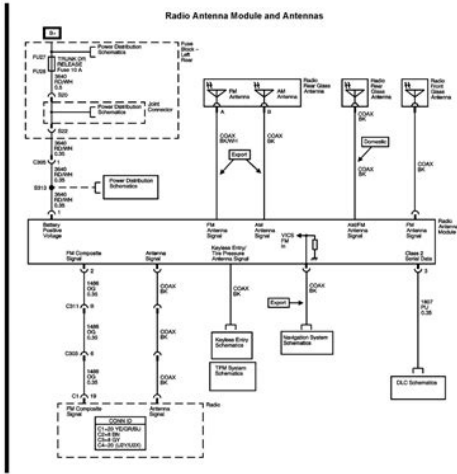

It also tells you some things you should collision, people riding in these areas are more not do with safety belts. Here is why They work. When you ride in or on anything, you go as fast as it goes. You never know if you will be in a crash. If you do have a crash, you do not know if it will be a bad one. The rider does not stop. 113. In a real vehicle, it could be the windshield. 114. You could be — whether you are wearing a safety belt or not. But you can unbuckle a safety belt, even if you are upside down. LapShoulder Belt You may be an excellent driver, but if you are in an The driver has a lapshoulder belt. Here is how to wear accident —. If this happens, let the belt go back slightly to unlock it. Then pull the belt across you more slowly. 4. Push the latch plate into the buckle until it clicks. Pull up on the latch plate to make sure it is secure. CAUTION You can be seriously hurt if your shoulder belt is too loose. In a crash, you would move forward too much, which could increase injury. The shoulder belt is too loose. It will not give nearly as much protection this way. CAUTION You can be seriously injured if your belt is buckled in the wrong place like this. In a crash, the belt would go up over your abdomen. The belt forces would be there, not at the pelvic bones. CAUTION You can be seriously injured if you wear the shoulder belt under your arm. In a crash, your body would move too far forward, which would increase the chance of head and neck injury. Also, the belt would apply too much force to the ribs, which are not as strong as shoulder bones. CAUTION You can be seriously injured by a twisted belt. In a crash, you would not have the full width of the belt to spread impact forces. Like all occupants, they are more likely to be seriously injured if they do not wear safety belts. To unlatch the belt, just push the button on the buckle. The belt should go back out of the way. Here is how to wear one properly. [http://lowfareairportcars.co.uk/home/saktc6/public\\_html/adminpanel/uploads/imagefile/dfas-in-manual-37-1.xml](http://lowfareairportcars.co.uk/home/saktc6/public_html/adminpanel/uploads/imagefile/dfas-in-manual-37-1.xml)

**2006 Cadillac CTS/CTS-V Owner Manual**

<b>Seats and Restraint Systems</b> .....	1-1	<b>Driver Information Center (DIC)</b> .....	3-53
Front Seats .....	1-2	Audio System(s) .....	3-83
Rear Seats .....	1-8	<b>Driving Your Vehicle</b> .....	4-1
Safety Belts .....	1-10	Your Driving, the Road, and Your Vehicle .....	4-2
Child Restraints .....	1-29	Towing .....	4-37
Airbag System .....	1-50	<b>Service and Appearance Care</b> .....	5-1
Restraint System Check .....	1-65	Service .....	5-3
<b>Features and Controls</b> .....	2-1	Fuel .....	5-5
Keys .....	2-3	Checking Things Under the Hood .....	5-10
Doors and Locks .....	2-8	Rear Axle .....	5-49
Windows .....	2-14	Headlamp Aiming .....	5-50
Theft-Deterrent Systems .....	2-18	Bulb Replacement .....	5-53
Starting and Operating Your Vehicle .....	2-22	Windshield Wiper Blade Replacement .....	5-56
Mirrors .....	2-39	Tires .....	5-58
OnStar® System .....	2-43	Appearance Care .....	5-94
Universal Home Remote System .....	2-45	Vehicle Identification .....	5-102
Storage Areas .....	2-49	Electrical System .....	5-103
Sunroof .....	2-51	Capacities and Specifications .....	5-114
Vehicle Personalization .....	2-52	<b>Maintenance Schedule</b> .....	6-1
<b>Instrument Panel</b> .....	3-1	Maintenance Schedule .....	6-2
Instrument Panel Overview .....	3-4	<b>Customer Assistance and Information</b> .....	7-1
Climate Controls .....	3-23	Customer Assistance and Information .....	7-2
Warning Lights, Gauges, and Indicators .....	3-30	Reporting Safety Defects .....	7-14
Message Center .....	3-47	<b>Index</b> .....	7-1

If the belt stops before it reaches the buckle, tilt the latch plate and keep pulling until you can buckle it. Pull up on the latch plate to make sure it is secure. If the belt is not long enough, see

Safety Belt 1. The lap part of the belt should be worn low and snug on the hips, just touching the thighs. In a crash, this applies force to the strong pelvic bones. When installed on You can be seriously hurt if your shoulder belt a shoulder belt, the comfort guide positions the belt is too loose. Then, place the guide The elastic cord must be under the belt and the over the belt and insert the two edges of the guide on top. The person wearing the belt could be seriously injured. The shoulder belt should go over the shoulder and across the chest. These parts of the body are best able to take belt restraining forces. Although you cannot see you should use it. An older child should wear a lap/shoulder belt and Older Children get the additional restraint a shoulder belt can provide. The shoulder belt should not cross the face or neck. If the child is sitting in a seat next to a window, move the child toward the center of the vehicle. This applies belt force to the child's pelvic bones in a crash. Infants and Young Children Everyone in a vehicle needs protection. This includes infants and all other children. Young children should not use the vehicle's adult safety belts alone, unless there is no other choice. Instead, they need to use a child restraint. CAUTION People should never hold a baby in their arms while riding in a vehicle. Airbags plus lap/shoulder belts offer protection for adults and older children, but not for young children and infants. Neither the vehicle's safety belt system nor its airbag system is designed for them. When purchasing a CAUTION child restraint, be sure it is designed to be used in a motor vehicle. If it is, the restraint will have a label saying that it meets federal motor vehicle The body structure of a young child is quite safety standards.

The harness system holds the infant in place and, in a crash, An infant car bed A, a special bed made for use in a acts to keep the infant positioned in the restraint. A builtin child restraint system is a CAUTION permanent part of the motor vehicle. The child restraint instructions are important, so if they are not available, obtain a replacement A child can be seriously injured or killed in a copy from the manufacturer. Even though the passenger sensing system is We recommend that child restraints be secured in a rear seat, including an infant riding in a rearfacing infant designed to turn off the passenger's frontal seat, a child riding in a forwardfacing child seat and. Children LATCH The child restraint manufacturer will provide you with instructions on how to use the child restraint and its The LATCH system holds a child restraint during attachments. A top tether A, C anchors the top of the child restraint There are two lower anchors for each LATCH seating to the vehicle. A top tether anchor is built into the position that will accommodate a child restraint with vehicle. Either will have a single attachment B Locations to secure the top tether to the anchor. Some child restraints with top tethers are designed Top Tether Anchor for use with or without the top tether being attached. Be sure to use an anchor located on the same side of the vehicle as the seating position where the child restraint will be placed. Attaching more than one child If a LATCHtype child restraint is not attached restraint to a single anchor could cause the to anchors, the restraint will not be able to anchor or attachment to come loose or even. When removing the child restraint, always remember to return the safety belts to their normal, stowed position before folding the rear seat. Children can be seriously injured or strangled if a shoulder belt is wrapped around their 1.

## Wiper System Power and Ground

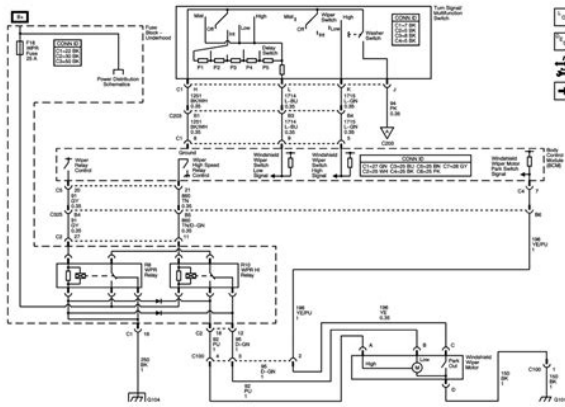

<https://congviendis.vn/vi/3m-peltor-powercom-plus-manual>

If your child restraint does not have the LATCH system, you will be using the lap/shoulder belt to secure the child restraint in this position. Be sure to follow the CAUTION Continued instructions that came with the child restraint. Secure the child in the child restraint when and as the If you need to secure a forwardfacing child instructions say. The child restraint instructions will show you how.

4. Buckle the belt. Make sure the release button is positioned so you would be able to unbuckle the safety belt quickly if you ever had to. If this happens, slightly recline the vehicle's seatback and adjust the seat cushion if possible. The right front passenger's frontal airbag is in the instrument panel on the passenger's side. The driver's frontal airbag is in the middle of the steering wheel. 156. Airbags should never be regarded as anything more than a supplement to safety belts, and then only in moderate to severe frontal or nearfrontal collisions In an impact of sufficient severity, the airbag sensing for the driver's and right front passenger's frontal system detects that the vehicle is in a crash. The driver's airbags are not part of the passenger Your vehicle has a passenger sensing system for the sensing system. The passenger airbag status indicator will be visible when you turn your ignition The passenger sensing system works with sensors that key to ON or START. A label on your sun visor says, CAUTION Continued "Never put a rearfacing child seat in the front." This is because the risk to the rearfacing child is so great, If you need to secure a forwardfacing child if the airbag deploys. If this happens, turn the vehicle off and ask the person to place the seatback in the fully upright position, then sit upright in the seat, centered on the seat cushion, with the person's legs comfortably extended.

<https://egrenage.com/images/bridgeport-j-head-repair-manual.pdf>

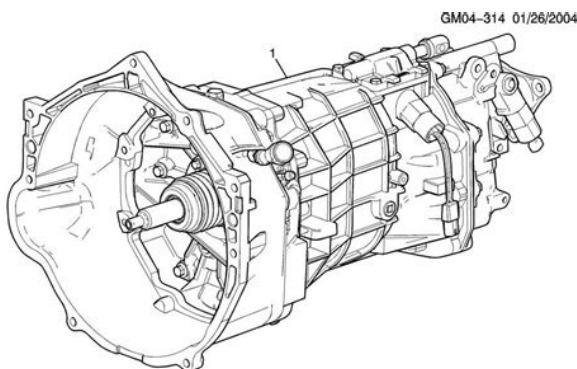

If the airbag readiness light in the instrument There are parts of the airbag system in several places panel cluster ever comes on and stays on, around your vehicle. Changing or moving any parts of the

front seats, Is there anything I might add to the front or safety belts, the airbag sensing and diagnostic sides of the vehicle that could keep the module, the inside rearview mirror, steering wheel,. After a Crash If belts are cut or damaged, replace them. Collision damage also may mean you will need to have LATCH system, safety belt or seat parts repaired or replaced. They could operate the power windows or other controls or even make the vehicle move. The children or others could be badly injured or even killed. Do not leave the keys in a vehicle with children. This is normal for any RKE system.If approximately one second to open the trunk. The remote keyless entry transmitter can be used to recall the memory settings for up to two drivers. You can tell the battery is weak if the transmitter won't work at the normal range in any location. If you have to get close to your vehicle before the transmitter works, it's probably time to change the battery. Because your vehicle has the theft-deterrent system, you must unlock the doors from the outside with the key Door Locks or Remote Keyless Entry RKE transmitter to avoid setting off the alarm. With this feature, you can delay the actual locking of When unlocking the driver's door, you can unlock the the doors.It can be dangerous to drive with the trunk lid open because carbon monoxide CO gas can come into your vehicle. You cannot see or smell CO. They can be overcome by the extreme heat and suffer permanent injuries or even death from heat stroke. Never leave a child, a helpless adult, or a pet alone in a vehicle, especially with the windows closed in warm or hot weather. Press the up or down arrows on the switches to raise or lower the windows.

<http://gtisupplies.com/images/bridgeport-j-series-milling-machine-manual.pdf>

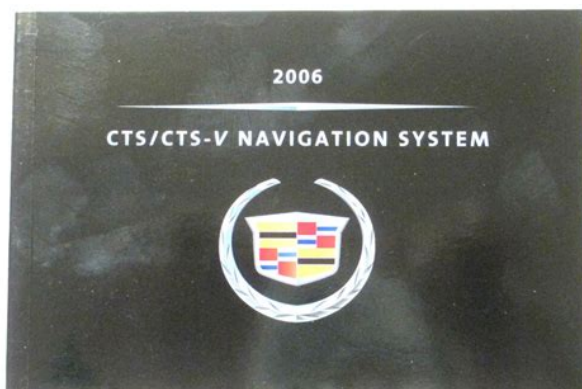

Your vehicle has Retained Accessory Power RAP that allows you to use the power windows for up to 10 minutes once the ignition has been turned off. To stop press and hold the down arrow on the power the window as it is lowering, press the down arrow window switch until the window has fully opened. CAUTION The passenger window lockout button is located If express override is activated, the window below the power window will not reverse automatically. You or others switches on the driver's could be injured and the window could be door armrest. It can If your vehicle has this also be detached from the center mount and moved feature, the security light is to the side to block glare from that direction.Your vehicle has a passive Operation is subject to the following two conditions theft-deterrent system. 1. This device may not cause interference. 2. This device must accept any interference received, including interference that may cause undesired operation. New Vehicle BreakIn Notice Your vehicle does not need an elaborate break-in.This position locks the ignition, Manual Transmission steering wheel and transmission. It is a theft-deterrent feature. The key cannot be B ACCESSORY This position allows you to use removed from the ignition things like the radio and the windshield wipers when the of manual transmission. This feature assists in starting the engine and protects the electrical system. If the Automatic Transmission ignition key is turned to the START position, and then released when the engine begins cranking, Move your shift lever to PARK P or NEUTRAL N. You will get easier starting could cause an electrical shock. Also, the and better fuel economy during engine warmup. Do not leave your vehicle when the engine is There are several

different running unless you have to. If you have left the positions for the shift lever. Then slowly let up on the clutch pedal as is located on the center console between the front you press the accelerator pedal.

SIXTH 6 the same way you do for SECOND 2. Slowly For the CTSV, your sixspeed manual transmission has let up on the clutch pedal as you press the accelerator a safety feature that prevents you from shifting into. When this message appears, you can only shift from FIRST 1 to If you skip a gear when you downshift, you FOURTH 4 instead of FIRST 1 to SECOND 2. To set the parking brake, hold the regular brake pedal To release the parking brake, pull the release lever down with your right foot and push the parking brake located to the left of the steering wheel on the pedal down with your left foot. It contains the gas carbon monoxide CO, which you cannot see or smell. It can cause unconsciousness and death. But if you ever have to, here are some things to know. If the vehicle has this feature, the mirror will display the word ON, or an airbag symbol in Canada, when the passenger airbag is enabled. Be sure to return both mirrors to their original unfolded position before driving. The control on the driver's If the vehicle has the memory package, the mirrors can door armrest operates both be programmed for personalization and curb view outside rearview mirrors. If you cut too sharply into the right lane, you could hit a vehicle on your right. Operation is subject to the following two conditions If your vehicle has this 1. This device may not cause harmful interference. When Operation programming a garage door, it is advised to park outside of the garage. Do not use the Universal Home Remote with any It is recommended that a new battery be installed in garage door opener that does not have the stop and your handheld transmitter for quicker and more. Locate the "Learn" noted in "Gate Operator and Canadian or "Smart" button. This can usually be found where Programming". The indicator light Canadian radiofrequency laws require transmitter will come on while the signal is being transmitted. They are located in the center console.

<http://www.nandomoraes.com.br/wp-content/plugins/formcraft/file-upload/server/content/files/1626f59b6a2da9---bosch-wfm-4030-manual.pdf>

To program a device to Universal Home Remote using a Universal Home Remote button previously trained, There are two cupholders located in the rear seat follow these steps center armrest. Open the doors to access these locations. Remove the plastic CAUTION cap before attaching a roof rack or luggage carrier. It provides less wind noise than the full open position. Your vehicle may have a power sunroof. It will operate Full Open Turn the control clockwise to this when the ignition is turned on, or in ACCESSORY, position to open the glass panel all the way. In an emergency, the antipinch feature can be overridden in a supervised mode. Each time a memory button is memory seat button 2 or the remote keyless pressed, a single beep will sound. See Audio Steering Wheel Controls CTS on C. The closer you move the band toward mist, the longer the delay. The windshield wiper lever must be in delay for this feature to work. Low Speed Put the lever in this position for slow, steady wiping cycles. The headlamp washers help clear the headlamp lenses. In freezing weather, do not use your washer The headlamp washers until the windshield is warmed. So, do not use your cruise control on winding roads or in heavy traffic. Cruise control can be dangerous on slippery roads. This, of course, CAUTION disengages the cruise control. But you do not need to reset it. The parking lamps must be on for the fog lamps to work. This protects against overhead console. Always unplug electrical equipment when not in use and do Your vehicle may have an ashtray and cigarette lighter. The vehicle does not have a cigarette lighter for the Dual Climate Control System rear seat passengers. With this system you can control the heating, cooling Notice Holding a cigarette lighter in while it is and ventilation for your vehicle. If you have the Base AUTO Automatic When this button is pressed and audio system, see DIC Main Menu on page 357.

If you the temperature is set, the system will automatically have the Navigation system, see "Setup Menu". It can be used to prevent Vent This mode directs air to the instrument outside air and odors

from entering your vehicle or panel outlets. In this mode, the system will automatically turn moisture condensing on the cool window glass. Be sure to clear symbol to use the side window defog setting. The air as much snow from the rear window as possible. Like your 2. Paying attention to the warning lights and gauges could also save you or Your vehicle may have four controls that can be others from injury. You will know how fast you are going, how much fuel you are using and many of the other things you will need to know to drive safely and economically. Per Minute RPM. The odometer shows how far your vehicle has been Notice If you operate the engine with the driven, in either miles used in the United States tachometer in the shaded warning area, your vehicle. The system their safety belts. Have your vehicle Your rearview mirror has a passenger airbag status serviced right away. Even though the passenger sensing system is CAUTION designed to turn off the passenger's frontal airbag if the system detects a rearfacing child restraint, no system is failsafe, and no one can If the on indicator comes on when you have a. See your dealer for service. The light will stay on if your parking brake does Your vehicle's hydraulic brake system is divided into not release fully. It will require at least You may be able to correct the emission system one full tank of the proper fuel to turn the light off. The repairs would not be emission control systems have not been completely covered by your warranty. Always follow the diagnosed by the system. The light will go out when the fog lamps are turned off. See Fog Lamps on page 319 for more information. It works only when the ignition is in the ON position. The light will go out when the cruise control is turned off.

See Traction Control System TCS CTS on page 49 or Traction Control System Message Center CTSV TCS CTSV on page 410 for more information. If the graph shows the pressure in the shaded area all the way to the left, then the oil When the coolant pressure is low. See Engine Oil on page 516 and temperature displays you DIC Warnings and Messages on page 361 for more will see the coolant. For example, when you are turning temperature displays you right you will feel your body push to the left. This will see the transmission force is measured in a "g". To acknowledge this warning, press either button on the outboard switch on the left spoke of the steering To acknowledge this warning, press either button on wheel. To acknowledge this warning, press either button on the To acknowledge this warning, press either button on the outboard switch on the left spoke of the steering outboard switch on the left spoke of the steering. FOURTH 4 instead of FIRST 1 to SECOND 2. All messages will appear on the audio system display. If your vehicle has the Base audio system, use the information contained in this manual for instructions on operating the DIC for your vehicle. When When you reset the Change Engine Oil message by the timer is off, the display will show the timer value clearing it from the display, you still must reset the and TIMER OFF. If the tire pressure is low, LOW will be displayed with this item. The pressure Accessing the DIC Main Menu can be displayed in pounds per square inch PSI or kilopascals KPA. These messages will appear if there is a problem The normal battery voltage range is 11.5 to 15.5 volts. detected in one of your vehicle's systems. You can monitor battery voltage on the DIC by pressing the INFO button until BATTERY VOLTS appears. If from damage due to extreme operating conditions. This message will display when a problem with the Try resetting the system by turning the ignition off and charging system has been detected.

Slippery road key is being used to try to start the vehicle. Check conditions may exist if this message is displayed, so the ignition key for damage. The letter will then appear on the display. The following choices are available for programming If you make a mistake, press the CLR button. This will exit the menu. You can then go back into Personalization Name the menu and edit the name. When this feature is turned on, you Mode 2 OFF can recall any previously programmed seat and mirror positions when the key is inserted into the ignition. You can either exit appear in the box next to the feature name. Mode 2 OFF To determine the mode to which the vehicle is Before your vehicle was shipped from the factory, it was programmed or to program the vehicle to a different. The feature allows the driver's door to automatically The mode you selected is now set. You can either exit



unlock when the transmission is shifted into PARK P. This feature allows the doors to automatically unlock. The mode you selected is now set. If your vehicle has the optional memory package, you When the mode is turned on, a check mark will will have this feature. When this feature is turned on, the appear next to the feature name. Here are some ways in which you can help operation of your vehicle's engine, radio, or other avoid distraction while driving. Your vehicle's systems may interfere with the operation of sound While your vehicle is parked equipment that has been added. If the system is set to LOCAL, SEEK will appear mode. SCAN will appear on the display. Press the in the display and seek to stations with strong signals up arrow to scan to the next station. To return to the original display, repeatedly press the CLR To set the preset stations with an equalization button or wait for the display to time out. To return 1. DSP NORMAL This setting provides the best overall audio performance for all passengers. DSP NORMAL 7. Press the CLR button to exit the display.

To will not appear on the display when in this mode. The system is working properly. No Info Category Name No category information is available at this time on this not available channel. Do not add any label to a CD, it could get caught in the Insert a CD partway into the slot, label side up. The CD player. The CD player can play the smaller 3 inch 8 cm single RANDOM will appear on the display. Press RDM again CDs with an adapter ring. The player will pull the CD in. Press this button again or turn the Controls CTS VOL knob to turn the sound on. If your vehicle has the navigation system, press Some audio functions can this button to initiate voice recognition. The longer range can cause vehicle's radio. This interference may occur when station frequencies to interfere with each other. For making or receiving phone calls, charging the phone's better radio reception, most AM radio stations will boost battery, or simply having the phone on. If this is true, the grid line Do not use CD lens cleaners for CD players because must be repaired. For persons under 21, Death and injury associated with drinking and driving it is against the law in every U.S. state to drink alcohol. Some people drive in spurts — heavy acceleration followed by heavy braking — rather than keeping pace with traffic. Your vehicle has the AntiLock Brake System ABS, This is a mistake. The brakes may not have time an advanced electronic braking system that will to cool between hard stops. As you brake, your computer keeps receiving updates Suddenly, an animal jumps out in front of you. You slam on wheel speed and controls braking pressure on the brakes and continue braking. Here is what accordingly. You may with your traction hear the antilock pump or motor operate, and feel the control system. Your vehicle has a Traction Control System TCS that limits wheel spin. This is especially useful in slippery road conditions.

To limit wheel system will turn off and the TCS warning light will spin, especially in slippery road conditions, you should come on. See DIC Warnings and Messages on page 361. Both control and easier to park. At faster speeds, the steering effort systems —. Remember that your vehicle's while you are awaiting an opportunity. For one thing, passenger side outside mirror is convex. The vehicle following too closely reduces your area of vision, you just passed may seem to be farther away from especially if you are following a larger vehicle. For example, if you spend the day in bright sunshine you are wise to wear sunglasses. Your eyes Night driving is more dangerous than day driving. Even if your windshield wiper blades are in good shape, a heavy rain can make it harder to see road signs and traffic signals, pavement markings, the edge of the road, and even people walking. So much water can build up under your tires that they can actually ride on CAUTION the water. This can happen if the road is wet enough and you are going fast enough. When your vehicle Flowing or rushing water creates strong is hydroplaning, it has little or no contact with the road. Get a city map and plan your trip into an unknown part of the city just as you would for a crosscountry trip. Drive at the same speed most of the other drivers are driving. Treat the left lane on a freeway as a passing lane. If you keep it you allow a reasonable following distance. If it needs service, have it done before starting out. Of course, Expect to move slightly slower at night. Or is it just plain falling asleep at the wheel. Call it highway hypnosis, lack of awareness, or whatever. There is something about an easy stretch of road with the same scenery, along with the hum of the tires on the road, the drone of the

engine, and the rush of the wind against the vehicle that can make you sleepy.

But wet ice Most of the time, those places where the tires meet can be even more trouble because it may offer the least the road probably have good traction. Even though you have ABS, you will a serious situation. This can cause deadly CO carbon monoxide gas to get inside. CO could overcome you and kill you. You cannot see it or smell it, so you might not know it is in your vehicle. This saves fuel. When you run the engine, make it go a little CAUTION faster than just idle. That is, push the accelerator slightly. This uses less fuel for the heat that you get and it keeps the battery charged. That will clear It is very important to know how much weight your the area around the front wheels. You should turn the vehicle can carry. Do not carry more than 132 lbs 60 kg in the trunk. CAUTION Do not load your vehicle any heavier than the Gross Vehicle Weight Rating GVWR, or either the maximum front or rear Gross Axle Weight Rating GAWR. If you have to stop or turn quickly, Towing Your Vehicle or if there is a crash, they will keep going. Consult your dealer or a professional towing service CAUTION if you need to have your disabled vehicle towed. Towing a Trailer Your vehicle is neither designed nor intended to tow any trailer. We hope you will go to your dealer including such things as, airbags, braking, stability, for all your service needs. It tells you much more about how to service your vehicle than this manual can. To order the proper service CAUTION manual, see Service Publications Ordering Information on page 716. To help avoid injuries to you and others, read and follow all the instructions on the pump island. Turn off your engine when you are refueling. Do not smoke if you are near fuel or refueling your vehicle. See DIC Warnings and Messages on page 361 for more information. If you spill fuel and then something ignites it, you could be badly burned.

<http://www.drupalitalia.org/node/79493>